

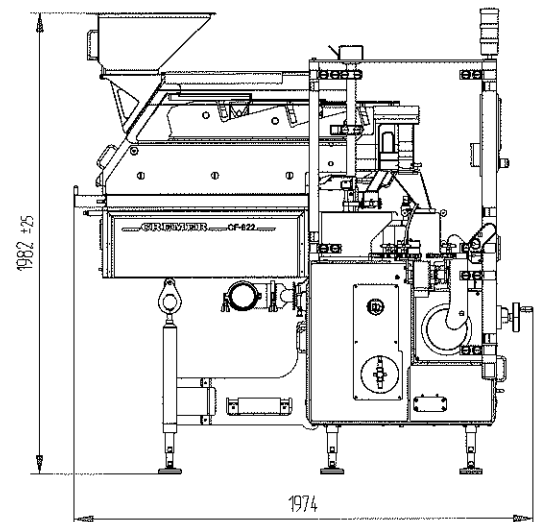

## Technical data

		<b>CFS-622*4</b>
<b>Configuration</b>	Counting modules	4
<b>Output</b>	Bottles / min (on average 100 count)	150
	Bottles / min (on average <60 count)	200
<b>Bottles</b>	Shape	Round, oval, square, rectangular
	Material	Glass, Plastic (HDPE, PETE)
	Height	35 - 200 mm (1.37 - 7.9")
	Diameter / width	20 - 125 mm (0.8 - 4.9")
<b>Solids</b>	Type	Tablets (coated and uncoated) , capsules, gencaps
	Length	3 - 30 mm (0.12 - 1.18")
	Diameter / width	3 - 20 mm (0.12 - 0.79")
<b>Electrical supply</b>	Input voltage	400 / 480 / 600 Vac
	Electrical connection	3 Phase + PE
	Max. power consumption	6000 VA
	<b>Air supply</b>	Compressed air supply
	Max. air consumption	10 NI/min.
<b>Machine dimensions</b>	L1	1680 mm (5.51')
	Weight (approx.)	1560 kg (3440 lb)

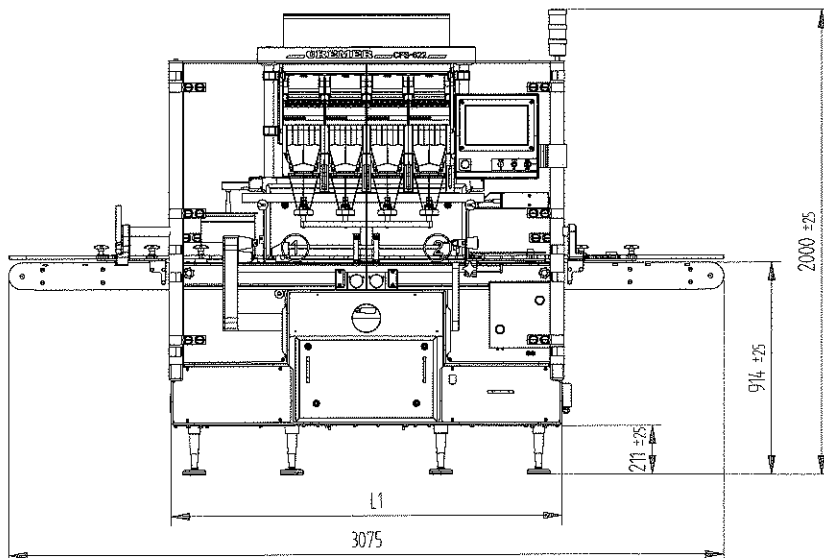



## Technical data

		<b>CFS-622*4</b>
<b>Configuration</b>	Counting modules	4
<b>Output</b>	Bottles / min (on average 100 count)	150
	Bottles / min (on average <60 count)	200
<b>Bottles</b>	Shape	Round, oval, square, rectangular
	Material	Glass, Plastic (HDPE, PETE)
	Height	35 - 200 mm (1.37 - 7.9")
	Diameter / width	20 - 125 mm (0.8 - 4.9")
<b>Solids</b>	Type	Tablets (coated and uncoated) , capsules, gelscaps
	Length	3 - 30 mm (0.12 - 1.18")
	Diameter / width	3 - 20 mm (0.12 - 0.79")
<b>Electrical supply</b>	Input voltage	400 / 480 / 600 Vac
	Electrical connection	3 Phase + PE
	Max. power consumption	6000 VA
	<b>Air supply</b>	Compressed air supply
	Max. air consumption	10 NI/min.
<b>Machine dimensions</b>	L1	1680 mm (5.51')
	Weight (approx.)	1560 kg (3440 lb)

