

# ProX™ 800

## 3D Production Printer



### Facility Guide

Original Instructions

# CONTENTS

<b>1</b>	<b>INTRODUCTION TO THE ProX™ 800</b> .....	<b>1</b>
	ProX 800 at a glance .....	1
	Material Delivery Module (MDM) .....	1
	ProCure™ 750 UV Curing Chamber .....	2
<b>2</b>	<b>CONTROLLER - PART PREPARATION SOFTWARE</b> .....	<b>2</b>
	Minimum Computer Requirements .....	2
	Processor .....	2
	Video Card .....	2
	RAM .....	2
<b>3</b>	<b>SITE SELECTION - ProX 800</b> .....	<b>3</b>
	Space Requirements .....	3
	Floor Area/Surface .....	3
	Floor Vibration and Shock .....	3
	Floor Bearing Capacity .....	5
	Electrical Requirements .....	5
	Connection to AC Power .....	5
	Temperature .....	5
	Humidity .....	5
	Altitude .....	7
	Overall Sound Pressure Level (OASPL) .....	7
	Air Cleanliness .....	7
	Lighting .....	7
	Door or Other Method of Preventing Access to Room .....	7
	Network Access .....	7
<b>4</b>	<b>SITE SELECTION: ProCure™ 750 UV CHAMBER</b> .....	<b>8</b>
	ProCure Space and Location Selection .....	8
	ProCure Floor Surface Requirements .....	8
	ProCure Electrical Requirements .....	8
	ProCure Ventilation (Ductwork) .....	8
<b>5</b>	<b>SYSTEM DELIVERY</b> .....	<b>10</b>
	Preparation for Receiving .....	10
	Shipment Arrival .....	10
	Inspect Exterior of Printer .....	11
	Inspect ShockWatch® Indicator .....	11
	Transporting the ProX 800 .....	12
	Third Party Supplies and Equipment .....	12
	Required Equipment .....	12
	Optional Equipment .....	12
	Support equipment which includes, but is not limited to: .....	13
	Recommended safety equipment and supplies: .....	13
<b>6</b>	<b>SYSTEM INSTALLATION</b> .....	<b>14</b>
	System Uncrating .....	14
	Scheduling Your Installation .....	14
	Preparing for System Installation .....	14
	Availability for Adequate Forklift or Lifting Equipment .....	14
	Minimum Passageway and Door Openings .....	14
<b>7</b>	<b>MATERIAL STORAGE AND SAFETY</b> .....	<b>15</b>
	Stereolithography Material Usage .....	15
	Material Storage .....	15
	Material Disposal .....	15
	Storage and Usage Guidelines .....	15

<b>8</b>	<b>APPENDIX A: INITIAL SITE SURVEY CHECKLIST</b> .....	<b>16</b>
<b>9</b>	<b>APPENDIX B: PRE-INSTALLATION PREPARATION CHECKLIST</b> .....	<b>17</b>
	Moving Equipment and Site Accessibility .....	17
	SLA System Area .....	17
	Part Finishing Area .....	17
	Waste Disposal and Safety .....	17
	Job Submission .....	17
<b>10</b>	<b>APPENDIX C: THIRD PARTY SUPPLIES AND EQUIPMENT</b> .....	<b>18</b>
	Part Washing Systems .....	18
	Uninterruptible Power Supply .....	18
	Hand-Held UV Guns .....	18
	Model Finishing Tools and Supplies .....	18
	UV Filter Screens (For Lights and Windows) .....	18
	Wipes .....	18
	Miscellaneous Supplies .....	18
<b>11</b>	<b>APPENDIX D: OBTAINING ASSISTANCE</b> .....	<b>19</b>
	U.S.A. ....	19
	Germany .....	19
	Hong Kong .....	19
	Italy .....	19
	Japan .....	19
	U.K. ....	19
	Switzerland .....	19
	France .....	19

# 1 INTRODUCTION TO THE ProX™ 800

The ProX™ 800 Stereolithography (SLA) Production Printer is equipped with 3D Systems' newest print head technology that can manufacture real parts at up to 10 times the speed of other 3D printers, drawing on the widest choice of proven high-performance engineered materials that are qualified for the most demanding aerospace, medical device and industrial-use cases.

The ProX 800 is flexible and versatile, and can produce precision parts with accuracy that rivals CNC machining. Like all 3D Systems SLA printers, it is exceptionally productive and economical for high-volume additive manufacturing of plastic parts.

With the industry's widest array of SLA materials, the ProX 800 delivers a range of properties, from ABS-like toughness to polycarbonate-like clarity. You can even cast directly from printed patterns using QuickCast® technology.

## ProX 800 AT A GLANCE

The ProX 800 is a flexible and efficient **stereolithography** (SLA) system that produces high fidelity parts from a broad range of plastics and composites. The ProX 800 uses an SLA platform that expands the overall utilization of SLA parts in prototyping and advanced digital manufacturing. Markets include automotive, service bureaus, aerospace, and consumer goods.

The ProX 800 is only one component of the complete system. Many accessories and other components make up a ProX 800 system:

## Material Delivery Module (MDM)

The **MDM** contains the material and is responsible for regulating the delivery of material to the printer. The MDM can be rolled in and out of the print chamber.

There are three MDM models:

NAME	MAXIMUM BUILD VOLUME	FILL CAPACITY
MDM 800-50mm	650 x 750 x 50 mm (25.6 x 29.5 x 1.97 in)	95 liters (25.1 U.S. gal)
MDM 800-275mm	650 x 750 x 275 mm (25.6 x 29.5 x 10.8 in)	272 liters (71.86 U.S. gal)
MDM 800-550mm	650 x 750 x 550 mm (25.6 x 29.5 x 21.65 in)	414 liters (109.3 U.S. gal)

Many customers order extra MDM units, particularly if they want to change material quickly or use two materials concurrently.



The ProX™ 800 Production Printer

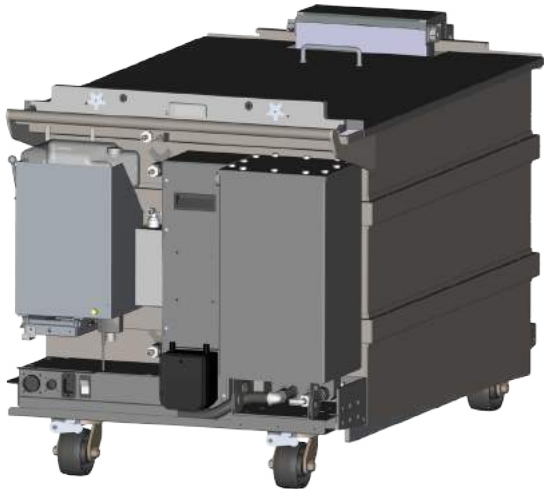

ProX 800 Material Delivery Module (MDM)

## Manual Offload Cart

The **manual offload cart** is an optional accessory for all ProX 800 models. The offload cart allows you to easily remove the print pad when it is loaded with a large or heavy part and transport it to the finishing area where supports are removed and the part is cleaned before it is cured.

All parts must be offloaded with the manual offload cart to ensure optimal safety.



Manual Offload Cart

## ProCure™ 750 UV Curing Chamber

The **ProCure 750 UV Chamber** is an optional accessory which provides essential final part curing to create a fully solidified part with stable mechanical properties and safe part handling. After printing on the SLA system, the part is washed and rinsed, then placed in this unit. Subjecting the part(s) to UV light for a period of time will fully solidify the part. After the part is removed from the unit, it is fully solidified and can be handled safely without gloves.



ProCure 750 UV Chamber

## 2 CONTROLLER - PART PREPARATION SOFTWARE

Included with the system is the **3DManage™** (for part preparation) and **Print3D Pro** software. These integrated modules provide part preparation and part printing functionality. Print3D Pro utilizes the ProX 800 controller computer, which is an integrated part of the ProX 800. The 3DManage software is installed on a separate computer provided by the customer.

### MINIMUM COMPUTER REQUIREMENTS

The following are the *minimum* computer configuration requirements for the part preparation computer to run 3D Manage:

#### Processor

- Pentium 4 2.4 GHz

#### Video Card

- OpenGL 1.4
- 128MB of graphics memory
- Native PCI express x 16 bus interface
- 1280 x 1024 Resolution

#### RAM

- 2 GB

### 3 SITE SELECTION - ProX 800

This section provides the requirements and recommendations to determine the most appropriate location for a highly functional, efficient ProX 800 workspace, with room for other equipment and supplies.

To help you choose a location, refer to [“Appendix A: Initial Site Survey Checklist” on page 16](#). This checklist provides the attributes that you need to select the best location for your installation.

After narrowing the list of possible locations, consider each requirement carefully before making a decision about your final placement site.

#### SPACE REQUIREMENTS

User preferences, building codes, and equipment configuration help you to define the total floor area that your ProX 800 will need. The SLA system should be located in an environmentally controlled room. Locate the secondary post processing equipment and supplies in an adjoining room or rooms, if possible. User preferences, building codes, required storage space, and other factors influence total room area. The illustration at the right shows an ideal site configuration that minimizes the required movement of parts after printing.

The illustrations, [“ProX 800 system space requirements” on page 4](#) show the minimum dimensions of the ProX 800 system. Your site layout will vary.



**NOTE:** Due to laser safety requirements, the system should be located where access to the room can be avoided during service calls.

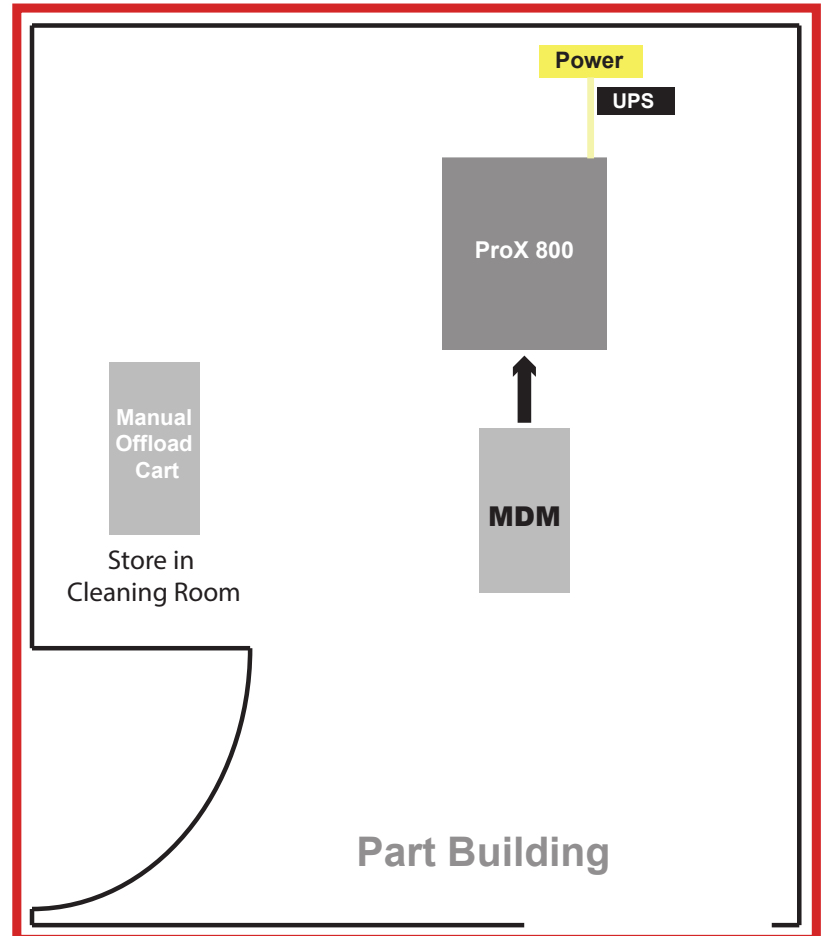

Optimal Site Layout

#### FLOOR AREA/SURFACE

Floors and counter spaces in the SLA work area should be non-porous and suitable for cleaning with solvents. The feet of the system must be on a non-resilient surface such as bare concrete. Carpeted floors must not be used. Remove any flooring where the feet of the SLA system will be placed. The system should not straddle any floor seams. The maximum permissible floor incline is 2.5cm/12m (1 in/40 ft).

#### FLOOR VIBRATION AND SHOCK

To ensure part quality and accuracy, choose a ground floor location with a thick concrete pad, which will minimize vibration. SLA equipment is slightly self-damping, and should not be affected by normal or incidental environmental vibration; however, the area should be isolated, either via location or some other physical or mechanical means, from any significant internal or external vibration sources such as heavy machinery, airplanes, or trains, which could cause unacceptable shock or vibration levels.

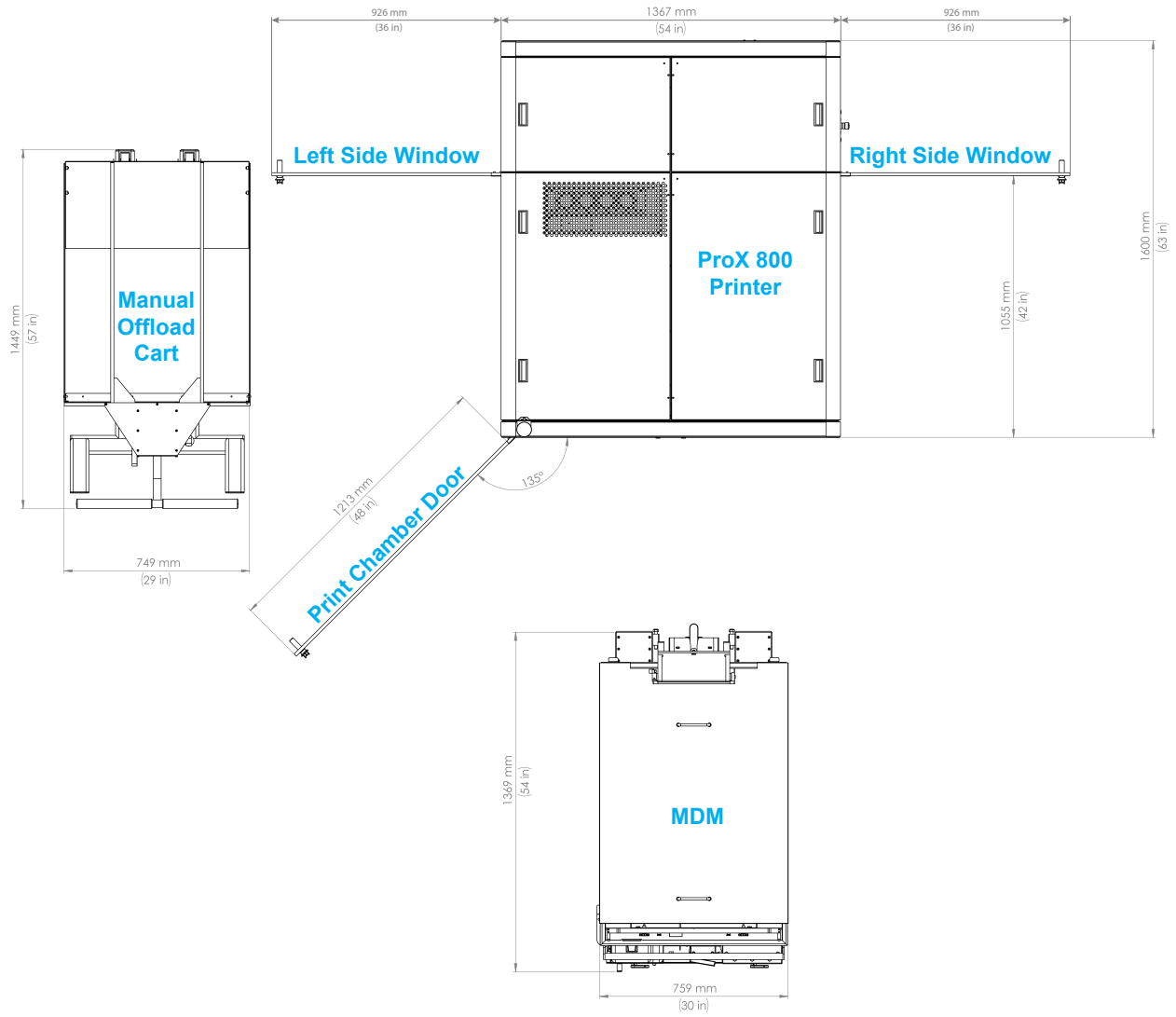

ProX 800 system space requirements (top view)

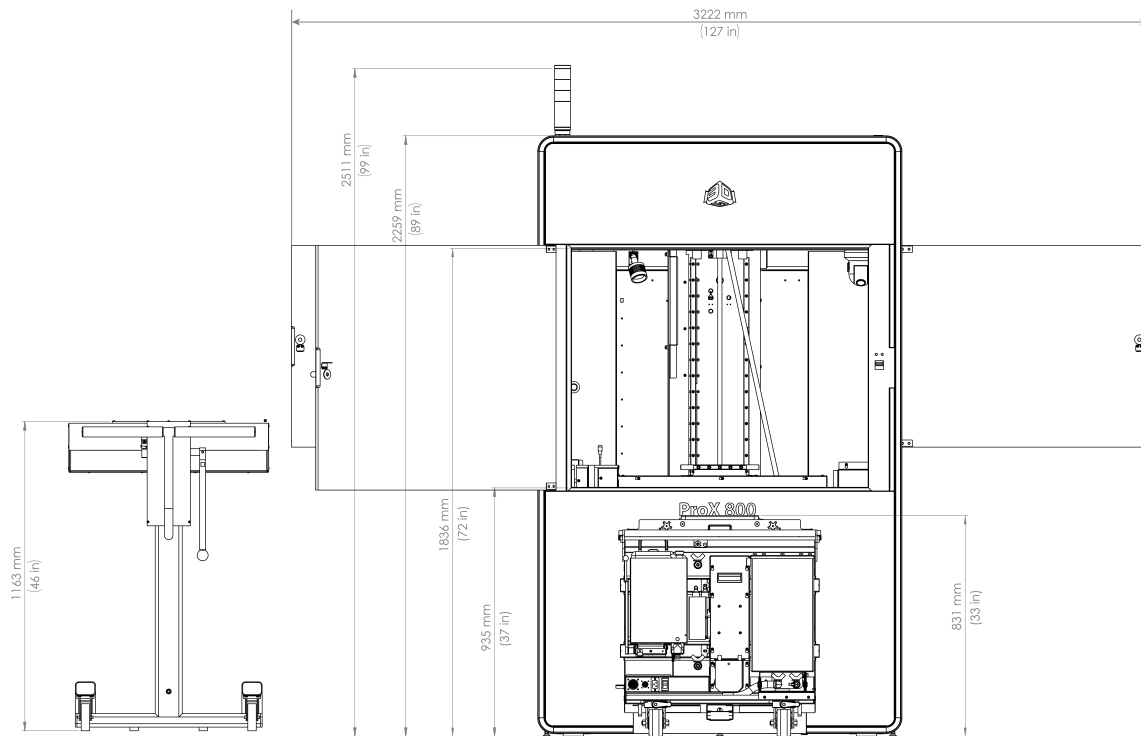

ProX 800 system space requirements (front view)

## FLOOR BEARING CAPACITY

The printer is the heaviest piece of equipment on the system, weighing 1134 kg (2500 lbs). Additional equipment, such as one or more Material Delivery Modules (MDM), will add significant weight as well. Refer to the illustration, [“Distributed Floor Load - ProX 800 and system components” on page 6](#) and the table, [“Weight and Dimensions - System Components” on page 10](#) to determine the total weight of the equipment to be housed in your room to ensure that you don't exceed the maximum load bearing capacity that your flooring can support.

## ELECTRICAL REQUIREMENTS

Electrical voltage requirements for the ProX 800 single MDM are:

- 220-240 VAC, 50/60 Hz, 30A, single-phase

The facility's power circuit must have a 30A-50A branch protective circuit breaker or fused disconnect with lockout/tagout capabilities. UPS usage is strongly recommended in areas where power fluctuations are frequent, as surges and spikes can cause damage to electronic components, and loss of power can result in failed prints or potential damage to the SLA system.

Surge and spike suppression should carry a rating of at least 1000 joules with a clamping voltage of approximately 300 VAC. Uninterruptible power, recommended especially in areas where circuits may be affected by lightning strikes, should be rated for 5kVA at a minimum. Make certain that no heavy equipment, especially large electric motors (greater than 1.5 kW or 2 hp) are connected to the same circuit. Use a pass-through UPS with power conditioning. For specific information on a suitable UPS, contact a UPS manufacturer and provide the voltage rating, current draw, and desired backup time. The manufacturer can recommend an appropriate model.

## CONNECTION TO AC POWER

The ProX 800 is designed to be connected to primary AC power directly from the facility's power circuit to the machine's main power disconnect. This task must be performed by a qualified electrician.

## TEMPERATURE

The temperature in the room or location where the SLA system resides should remain stable to allow optimal system operation and optimal part quality.

The working range is: 20-26 °C (68-79 °F)

Any temperature fluctuations greater than 3 °C (5 °F) may adversely affect parts built on the system. The rate of temperature change should not exceed 1 °C (1.8 °F) per hour. The air conditioning system should maintain a temperature change of less than 1 °C per hour. The stereolithography room should have a minimum cooling capacity of 1.4 kW. The air should change two to five times per hour. Avoid exposure of the SLA system to direct air flow from the local air conditioning system to avoid the possibility of adversely affecting part quality.

## HUMIDITY

The optimal humidity in the ProX 800 print chamber and lab will depend to a certain degree on the material selection used for printing. Regardless, the humidity should always be non-condensing and should not vary outside the range of 20-50%. Review your material information (MSDS/SDS, product datasheet, and product labeling) for specific information on recommended humidity levels.



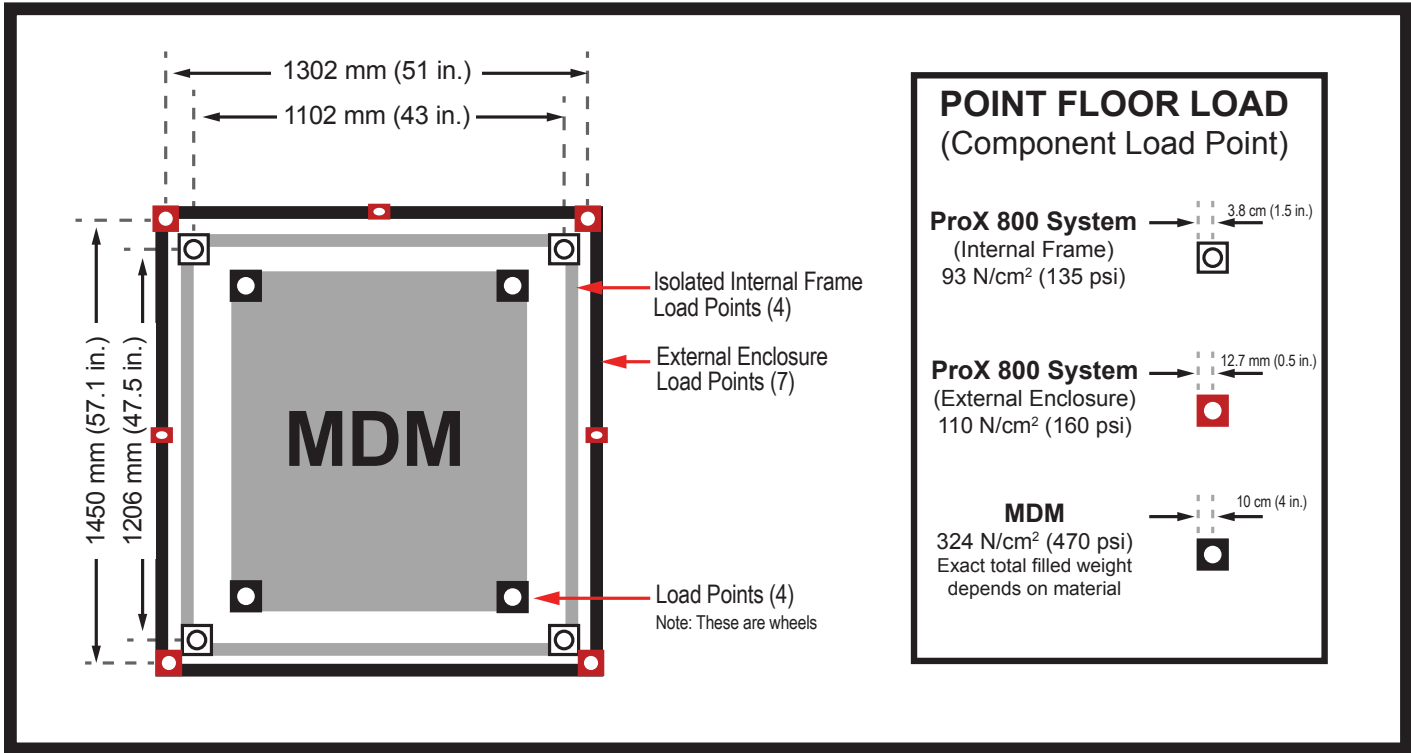

Distributed Floor Load - ProX 800 and system components

## **ALTITUDE**

The SLA system is capable of operating correctly up to an altitude of 1000m above mean sea level.

## **OVERALL SOUND PRESSURE LEVEL (OASPL)**

The sound of the SLA system will not exceed 70 dBA.

## **AIR CLEANLINESS**

The room housing the SLA system should be well ventilated. Reasonable care should be taken to minimize dust and smoke which could contaminate the material and cause deterioration of optical surfaces. Avoid temperature fluctuation. Since dust, smoke and temperature fluctuations can affect the performance of the machine and the quality of the parts, a restricted area with positive pressure filtered air flow is recommended. Avoid proximity to machine shop areas, or where milling, grinding, or sanding is performed.

## **LIGHTING**

Standard fluorescent lamps with clear plastic diffusers are recommended to minimize ultraviolet exposure, which could negatively affect the printing material. Sunlight, quartz-halogen lamps, and high-intensity incandescent lamps are not suitable, and UV-intensive lighting or ultraviolet exposure through windows should be avoided. UV filters are available for windows and exposed fluorescent lamps.

## **DOOR OR OTHER METHOD OF PREVENTING ACCESS TO ROOM**

The site should be able to be isolated from other employees or personnel during installation or future service calls. A separate room or area that can be closed to others is necessary. The system is safe and does not present hazards to properly trained personnel operating the system in accordance with our specifications. However, the system should be installed in an area that can be cleared of untrained personnel during service and maintenance of the machine due to laser safety requirements.

## **NETWORK ACCESS**

The SLA system controller computer includes a Class A Ethernet interface, which can be connected to a 10/100/1000 Gigabit Ethernet network to offer network access to the SLA system. A cable that is 6 m long is supplied with the ProX 800. To remotely operate the ProX 800 or to remotely run service engineer diagnostics, a VPN network access is required.

## 4 SITE SELECTION: ProCure™ 750 UV CHAMBER

Locating the ProCure 750 UV Chamber is similar in many respects to the ProX 800. The following abbreviated site specifications are for the ProCure UV Chamber:

### ProCure SPACE AND LOCATION SELECTION

The ProCure UV Chamber should be located in an appropriate room or location adjoining the ProX 800. Refer to the illustration, [“Optimal Site Layout” on page 3](#) for a suggested overall layout. Refer to the table, [“Weight and Dimensions - System Components” on page 10](#) for weights and measurements, as well as the illustration, [“ProCure 750 UV Chamber Dimensions” on page 9](#). Consider the following additional specifications when selecting the location for your ProCure unit:

Recommended floor space	7 m x 4.5 m	12 ft x 15 ft
Minimum ceiling height	244 cm	96 in
Recommended ceiling height	305 cm	120 in

### ProCure FLOOR SURFACE REQUIREMENTS

Flooring under the ProCure UV Chamber should be non-porous and suitable for cleaning with solvents. Carpeted floors are not recommended.

### ProCure ELECTRICAL REQUIREMENTS

Specification - either of these two power configurations:

- 110 VAC, 50/60 Hz, 13A
- 220 VAC, 50/60 Hz, 7A

The ProCure UV Chamber is equipped with a standard IEC 60320 C14 3-wire power cord inlet, and a USA plug with an IEC 60320 C13 outlet.

Electrical power for the ProCure UV Chamber must be on a dedicated, surge protected circuit. We strongly recommend an Uninterruptible Power Supply (UPS) in areas with frequent power fluctuations; surges and spikes can damage electronic components and power loss can damage the unit.



IEC 60320 C13 connector and C14 inlet are rated 10A (VDE) and 15A (UL & CSA)

### ProCure VENTILATION (DUCTWORK)

The ProCure UV Curing Chamber may be vented outside if required or appropriate. The left side of the unit has a built-in exhaust fan, and includes an 8” diameter duct connector.

If the curing chamber duct is joined to a duct that has positive pressure, an extraction system should be installed, regardless of duct length. Flow restriction from a 90 degree elbow equals 5.1 m (17 ft) of duct. If the exhaust run exceeds the 60 m (200 ft) limit, an extraction system or auxiliary fan should be installed. Contact your Facilities Manager for your requirements.



**Caution: Never disconnect a ducting system that is connected to an external extraction system.**

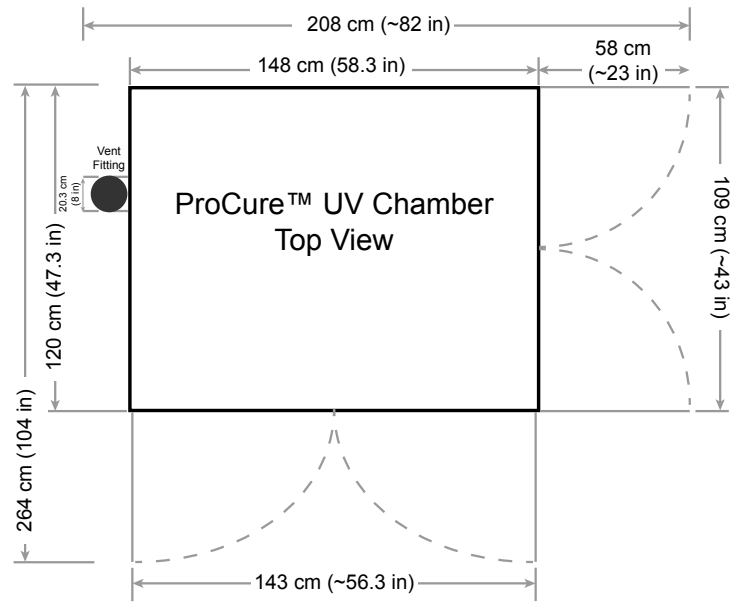
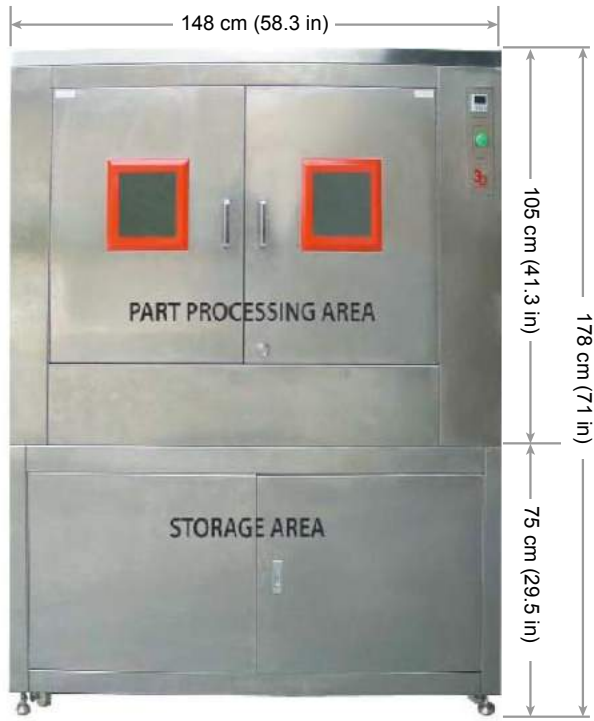

## 5 SYSTEM DELIVERY

After placing your order, a 3D Systems representative will contact you to schedule your shipment delivery date. Ensure that the area into which you intend to place your SLA system is ready, and that you have appropriate forklifts or other lifting devices before scheduling the installation of your system by a 3D Systems representative. The following information will guide you through this preparation phase.

### PREPARATION FOR RECEIVING

Being that the ProX 800 crate is quite large, have an adequate forklift available before you begin to unload the crate from the shipping truck. Make sure that the available forklift, or other lifting device, can handle the load during unloading and during uncrating. Refer to the illustration, [“Forklift lift points - ProX 800 Printer” on page 12](#) for locations and dimensions for the forklift.



**NOTE: Crates can only be unpacked by, or under the supervision of, a 3D Systems Customer Support Engineer. 3D Systems accepts no responsibility for missing items if crates are opened without an authorized Customer Support Engineer present supervising this procedure.**

Inform your receiving personnel that these crates will be arriving and arrange for a location to store them in until your appointment with a 3D Systems Customer Support Engineer.

Inform your receiving personnel that the crates allow forklift access from the side to make sure they can be properly unloaded or moved to your warehouse until the 3D Systems representative is scheduled to install the systems.

If you do not have an adequate forklift on-site, contact the shipping company in advance of the shipment to discuss whether one is needed for receiving the shipment.



**NOTE: The forklift must have a minimum of 1.8m (6 ft) forks for safe and stable transport, but we recommend 2m (6.5 ft).**

It must be rated for the weight of any of the components you ordered. The lift loops are designed to accept 1.5 in (38 mm) thick, 4 in (approximately 100 mm) wide forks. Fork extensions will not fit in the lift loops on the machine frame. Review the charts below for crated dimensions and weights of the components.

### SHIPMENT ARRIVAL

The ProX 800 system will arrive in a variety of crates and/or pallets - the largest crate being the ProX 800.

Once your shipment arrives, first inspect the crates for any physical damage. Then, after inspection, receive the crates.

The following chart lists both crated and uncrated dimensions and weights for every possible crate that you may have ordered. Verify your order and compare to the listed items below. Crates or pallet dimensions and weights may vary.

Description	Crated Specifications								Uncrated Specifications							
	Width		Depth		Height		Weight		Width		Depth		Height		Weight	
	cm	in	cm	in	cm	in	kg	lb	cm	in	cm	in	cm	in	kg	lb
ProX 800	163	64	189	74.5	248	98	1134	2500	137	54	160	63	226	89	907	2000
Laser Unit (laser, power supply)	94	37	64	25	89	35	91	200	19	7.5	53	20.9	17	6.7	22.7	50
Manual Offload Cart	127	50	174	68.5	157.5	62	160	350	76	29.8	140	55.1	118	46.3	90	200
ProCure 750 UV Chamber	154	60.8	138	54.5	172.7	68	522	1150	148	58.3	120	47.2	178	70.1	431	950
MDM 800-50mm 95 liters	182	72	136	54	110	44	182	400	78	30.7	143	56.3	78	30.7	136	300
MDM 800-275mm 272 liters	182	72	136	54	110	44	182	400	78	30.7	143	56.3	78	30.7	136	300
MDM 800-550mm 414 liters	182	72	136	54	110	44	182	400	78	30.7	143	56.3	78	30.7	136	300

Weight and Dimensions - System Components

## Inspect Exterior of Printer

Visually inspect the exterior of the printer for any damage incurred during shipping. Notify 3D Systems Service immediately if anything is evident at this point. DO NOT proceed with the installation until you have discussed the damage with Service.

## Inspect ShockWatch® Indicator

Check the ShockWatch indicators (towards top of crate and at bottom of crate).

If indicator(s) are red:

1. Do not refuse shipment.
2. Make notation on delivery receipt and inspect the container for signs of damage.
3. If damage is discovered, leave item in original container and packaging, and request immediate inspection from carrier within 15 days from delivery date.

If indicator is not red, machine is cleared to uncrate by a 3D Systems Field Service Engineer or an authorized reseller.



## TRANSPORTING THE ProX 800

When the 3D Systems Field Engineer arrives, and the crate is opened, use a forklift to lift the system. Refer to the following diagram illustrating the forklift points.

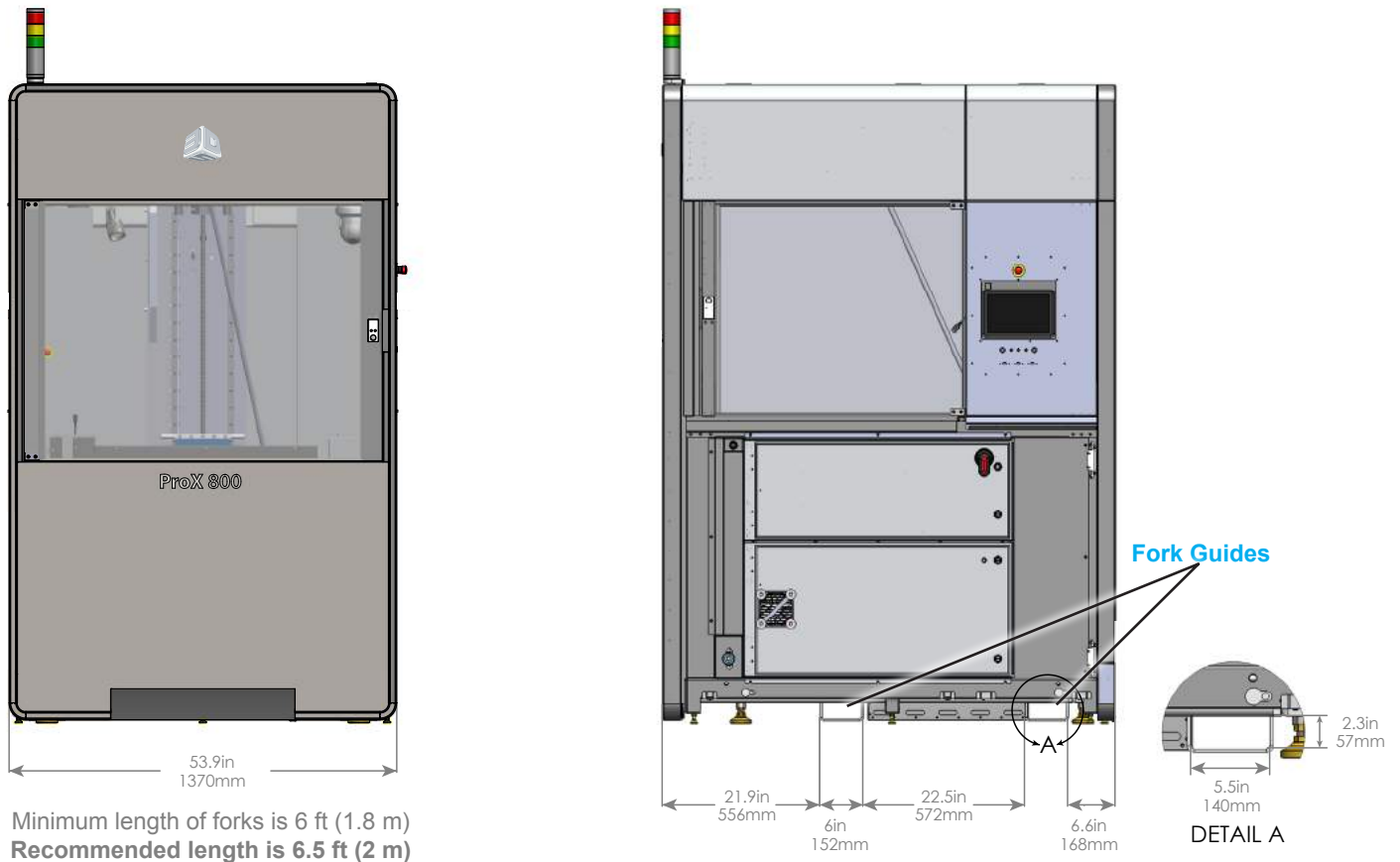

Forklift lift points - ProX 800 Printer

## Third Party Supplies and Equipment

Third party supplies and equipment are purchased from parties other than 3D Systems. These components are recommended or required for full post-processing capability. These items should be found and delivered prior to the installation of your ProX 800. Your 3D Systems representative can offer guidance regarding optimal placement and location of this equipment.

For a partial list of providers for this equipment, refer to [“Appendix C: Third Party Supplies and Equipment” on page 18](#).

These supplies, accessories, and equipment provide SLA system owners with complete part-building, processing, and finishing capability.

### Required Equipment

- SLA part post-processing equipment and supplies. Refer to the section, [“Support equipment which includes, but is not limited to” on page 13](#).
- Safety equipment. Refer to the section, [“Recommended safety equipment and supplies” on page 13](#).
- One or more Windows 7-equipped workstations. At least one system must be available at installation time to load this computer with 3D Systems' 3DManage software. Ask your 3D Systems representative about loading this software in advance of your installation appointment.

### Optional Equipment

- Uninterruptible Power Supply (UPS) and any miscellaneous cables or cords - minimum rating of 5kVA for the ProX 800.
- Functioning network connection for a computer to the SLA system. If no network is available, ensure a computer is in close proximity to the SLA system during your installation appointment.

**Support equipment which includes, but is not limited to:**

- Part cleaning and finishing equipment - this may be a very simple system, or more complex, depending on your needs and space. Minimally, two covered tubs are needed to accommodate ProX 800 print pads so that the parts may be washed and rinsed after building.
- Sink(s).
- Resin storage cabinet.
- Workbench—for processing parts and removing supports—“green” area and clean area with down-draft table for sanding.
- Any desired post-processing equipment—to sand, join, grind, polish, paint or plate SLA parts.
- Compressed air connection with pressure controller and fast-closing connection for part finishing, if desired.

**Recommended safety equipment and supplies:**

- Fire extinguishers.



**Use National Fire Protection Association Class B extinguishers such as carbon dioxide, dry chemical, or foam.**

- Smoke alarm in room.
- Eyewash stations.
- Protective clothing, including chemical-resistant nitrile gloves and lab coats with long sleeves.
- Safety eye glasses with side shields and UV coating.
- Hazardous waste cans for chemicals



Installation of your system encompasses four separate steps:

1. Purchase and arrival of third party equipment or supplies you may have ordered.
2. Scheduling your installation with a 3D Systems representative.
3. Delivery of your SLA system shipment.
4. Uncrating and installation of your SLA system components.

## SYSTEM UNCRATING

Your 3D Systems Field Service Representative will supervise or perform all crate unpacking. A 3D Systems representative will contact you and schedule an appointment to install your system; do not open crates until the 3D Systems representative arrives to personally uncrate and install the system.



**NOTE: 3D Systems cannot assume responsibility for contents of the crates if they are opened without 3D Systems' supervision.**

## SCHEDULING YOUR INSTALLATION

The 3D Systems authorized representative will schedule an appointment with you to install all the components and products purchased with your ProX 800. Allow a minimum of one week for your system installation, but discuss the expected installation duration with your 3D Systems representative; every situation is unique and installation depends on equipment, location, and other factors.

### Preparing for System Installation

In preparing your facility for SLA system placement, you must consider four main factors:

- Make sure that you have the necessary doorway and passageway clearance to move either the crated or uncrated components to their final destinations.
- Make sure that you have an adequate forklift and a trained forklift driver or other lifting equipment that can move oversized system components - either crated or uncrated.
- Verify that the lifting equipment is rated for the load from the system components.
- Do not allow the system weight load to exceed your floor's load rating maximum.

### Availability for Adequate Forklift or Lifting Equipment

You must have a forklift and a trained forklift driver available during installation. Make sure that the forklift is rated to a weight capacity that is equal to or greater than the crated weight of the SLA system. Refer to the table, [“Weight and Dimensions - System Components” on page 10](#) and the illustration, [“Forklift lift points - ProX 800 Printer” on page 12](#).

The ProX 800 is crated so that it can be lifted from the narrow end. Regardless, the forklift must meet minimum weight requirements and be equipped with 1.8 m (6 ft) forks (2.0 m (6.5 ft) is recommended) and typically carry a rating of at least 1134 kg (2500 lbs) for the ProX 800 that is crated and 907 kg (2000 lbs) uncrated. **Be very careful not to tilt the crate.**

The **fork guides** have the following inner dimensions (Detail A in the illustration, [“Forklift lift points - ProX 800 Printer” on page 12](#)):

- *Width:* 5.5 in (140mm)
- *Height:* 2.3 in (57mm)

The center of gravity for the ProX 800 is located at approximately the center of the shipping crate.

### Minimum Passageway and Door Openings

Most standard doorways and halls provide adequate access for moving the system. Considering the ProX 800 (crated) is lifted on its narrow side, each passageway and doorway must be wide enough to move and turn a crate measuring: 163 cm (64 in) wide, 189 cm (74.5 in) deep, and 248 cm (98 in) high for the ProX 800 in addition to the forklift.

Determine the pathway to where your SLA system will be installed from where the crated components are stored. Walk the path from the storage location to the final destination of the system, and measure any critical doorways or passageways to ensure that the equipment can be moved through the area.

If a passageway or doorway is too small for the crated SLA system, it may be necessary for the 3D Systems Field Service Engineer to remove the SLA system from its crate before moving the unit.

The minimum height of the doorway must be 228.6 cm (90 in), which will allow a 1.3 cm (0.5 in) clearance when the *uncrated* ProX 800 is lifted 1.3 cm (0.5 in.) off the floor. Any lift requirements greater than 1.3 cm (0.5 in) will require additional door height.

## 7 MATERIAL STORAGE AND SAFETY



**NOTE: The ProX 800 User Guide contains the full scope of safety information that applies to your SLA system. Read through the User Guide before operating any equipment or handling any material.**

You are responsible for ensuring that the facility where your SLA system and printing materials are housed is properly configured for safe operation of the SLA system and of the materials used in that system. Personnel who operate the equipment or use the materials must comply with all relevant safety codes and applicable regulatory requirements and laws, particularly those that relate to usage of hazardous chemicals, laser radiation, and to disposal of regulated material. The system conforms to Federal Laser Product Performance Standards 21CFR1040.10 Class I laser in normal operation and/or bypass mode. During field service, during which only trained service engineers have access to the SLA system, emission levels correspond to a Class IV laser product. The ProX 800 complies with CE requirements.



**NOTE: You are responsible for determining whether additional supplies and equipment are necessary according to local, state, federal or other regulatory laws that govern your location.**

### STEREOLITHOGRAPHY MATERIAL USAGE

SLA materials in the liquid state require use of approved surgical-type 100% nitrile gloves and other equipment to protect the user from direct contact with the uncured, or liquid, material. In general, liquid material is fully cured only after adequate exposure in the ProCure UV chamber; only after being fully cured, do the parts no longer require protective gloves to handle.

### MATERIAL STORAGE

Prior to actual use of the material, read the Material Safety Data Sheet / Safety Data Sheet (MSDS/SDS) for the material(s) that you have selected; follow the instructions and guidelines that those documents provide. You may also refer to the resin manufacturers' material safety and handling guides for more information about material handling.

### MATERIAL DISPOSAL

Because stereolithography materials are regulated, they are subject to special disposal requirements by your local, federal, or other regulatory agencies. Follow applicable disposal guidelines. Contact a local waste management company for recommendations on disposal requirements that affect your facility.

Do not leave uncured, or liquid, materials in an area where persons who are not knowledgeable about their handling or use may have access to them. If your area requires a regulated waste disposal, consult with and retain a waste management company to periodically pick up regulated waste. Your local waste management company may recommend that you set up a drum, or other approved container, to dispose of liquid print material and of any materials (such as paper towels or gloves) that may have come into contact with the uncured liquid print material.

After part building in the SLA system, the parts are not yet fully cured, and must be post-cured using the ProCure UV Chamber. After an adequate period of UV light exposure in the ProCure chamber, the parts should be fully solidified and then may be handled without the precaution of gloves.



**NOTE: Inspect your parts after curing in the ProCure UV chamber to ensure they are fully solidified. Part surface tackiness, visible or discernible areas of liquid resin indicate the part is not fully cured.**

#### Storage and Usage Guidelines

- Always wear appropriate safety equipment, such as 100% nitrile gloves when handling uncured liquid print material. Protect your body from any direct contact with uncured print material.
- Always read the MSDS/SDS prior to use of any print material.
- Always use the oldest SLA material first. All materials have a shelf life, usually one year from the date of manufacture. Using the oldest material first helps you to use all your purchased materials within that period of time.
- During storage, shield the SLA material from sunlight or other sources of actinic radiation, such as fluorescent or mercury vapor lights. Exposing the print material to UV radiation increases product viscosity and polymerization, making the SLA material unsuitable for part building. Storing print material above the maximum recommended temperature can make the it unsuitable for part building.
- Keep the storage area away from ammonia.
- Store containers of SLA materials indoors at temperatures between 16 °C (60 °F) and 27 °C (80 °F). Storing at temperatures above this maximum could render the material unusable for part building.

# 8 APPENDIX A: INITIAL SITE SURVEY CHECKLIST

Survey the areas where you have considered placing your new SLA system. Consider the following factors before you decide on your ProX 800 facility.

Option 1

---

Option 2

---

Option 3

---

Option			
1	2	3	
<input type="checkbox"/>	<input type="checkbox"/>	<input type="checkbox"/>	Is there enough space for all equipment in that area, or will you separate the SLA system from the secondary finishing equipment? (Refer to the section, <a href="#">“Optimal Site Layout” on page 3</a> )
<input type="checkbox"/>	<input type="checkbox"/>	<input type="checkbox"/>	Is the flooring a solid, nonporous surface suitable for cleaning with isopropyl alcohol? (Refer to the section, <a href="#">“Floor Area/Surface” on page 3</a> )
<input type="checkbox"/>	<input type="checkbox"/>	<input type="checkbox"/>	Can the location be isolated, as a laser safety precaution? Can closing and locking the door during installation or a service call prevent access to the location by unauthorized personnel? (Refer to the note in the section, <a href="#">“Space Requirements” on page 3</a> )
<input type="checkbox"/>	<input type="checkbox"/>	<input type="checkbox"/>	Can the required equipment and accessories be located either in the same room or in an adjoining room to the ProX 800? (Refer to the section, <a href="#">“Optimal Site Layout” on page 3</a> )
<input type="checkbox"/>	<input type="checkbox"/>	<input type="checkbox"/>	Is the air conditioning adequate for that area? (Refer to the section, <a href="#">“Temperature” on page 5</a> )
<input type="checkbox"/>	<input type="checkbox"/>	<input type="checkbox"/>	Can humidity be maintained at an appropriate non-condensing level for the SLA material (20-50%)? (Refer to the section, <a href="#">“Humidity” on page 5</a> )
<input type="checkbox"/>	<input type="checkbox"/>	<input type="checkbox"/>	Is adequate electrical power available to the site? Are there at least two 220 V circuits; two outlets, each with its own circuit and at least one additional 110/220 V outlet for servicing the system? (Refer to the sections, <a href="#">“Electrical Requirements” on page 5</a> and <a href="#">“ProCure Electrical Requirements” on page 8</a> )
<input type="checkbox"/>	<input type="checkbox"/>	<input type="checkbox"/>	Is there minimal UV-intensive lighting or natural sunlight? (Refer to the section, <a href="#">“Lighting” on page 7</a> )
<input type="checkbox"/>	<input type="checkbox"/>	<input type="checkbox"/>	Is 10/100/1000 BASE-T Ethernet network and cabling installed to the location? (Refer to the section, <a href="#">“Network Access” on page 7</a> )
<input type="checkbox"/>	<input type="checkbox"/>	<input type="checkbox"/>	Is the room clean? Is construction of floors, ceilings, and walls complete? (Refer to the section, <a href="#">“Air Cleanliness” on page 7</a> )
<input type="checkbox"/>	<input type="checkbox"/>	<input type="checkbox"/>	Is an appropriate forklift available during the installation appointment to move the system and its accessories to their designated location? (Refer to the section, <a href="#">“Availability for Adequate Forklift or Lifting Equipment” on page 14</a> )
<input type="checkbox"/>	<input type="checkbox"/>	<input type="checkbox"/>	Are the hallways and doorways adequate to allow passage of a forklift carrying a crated or uncrated SLA system? (Refer to the section, <a href="#">“Minimum Passageway and Door Openings” on page 14</a> )
<input type="checkbox"/>	<input type="checkbox"/>	<input type="checkbox"/>	<ul style="list-style-type: none"> <li>• ProCure UV Chamber?</li> </ul>
<input type="checkbox"/>	<input type="checkbox"/>	<input type="checkbox"/>	<ul style="list-style-type: none"> <li>• Bench for cleaning parts?</li> </ul>
<input type="checkbox"/>	<input type="checkbox"/>	<input type="checkbox"/>	<ul style="list-style-type: none"> <li>• Green part rinsing and finishing area?</li> </ul>
<input type="checkbox"/>	<input type="checkbox"/>	<input type="checkbox"/>	<ul style="list-style-type: none"> <li>• Sink and eyewash station?</li> </ul>
<input type="checkbox"/>	<input type="checkbox"/>	<input type="checkbox"/>	Is there a compressed air connection with pressure controller and fast-closing connection? (Optional)

## APPENDIX B: PRE-INSTALLATION PREPARATION CHECKLIST

The following list helps you to prepare for your ProX 800. Prior to scheduling the installation appointment with a 3D Systems representative, complete the checklist and fax it to your 3D Systems Customer Support Engineer.

### MOVING EQUIPMENT AND SITE ACCESSIBILITY

- Is there an adequately rated forklift available during installation to move the equipment to its destination?
- Have you coordinated the move with your shipping department?
- Is there adequate doorway and hallway clearance to move system components using available moving equipment?

### SLA SYSTEM AREA

- Is adequate space available for the equipment and supplies? (See the section, "[Site Selection](#)" on page 3)
- Is the site prepared properly? (See the section, "[Site Selection](#)" on page 3)
- Are the following electrical power outlets in place?
  - For the ProX 800: Do the electrical power requirements meet the specifications in "[Electrical Requirements](#)" on page 5?
  - For service and other uses: Are there two additional outlets, 110/220 V?
- In the room where the ProX 800 will be installed, does the air conditioning meet the following requirements?
  - Is there a minimum cooling capacity of 3.6 kW in the room?
  - Is the temperature change less than 1° C (1.8 °F) per hour?
  - Is humidity maintained at an appropriate non-condensing level for the resin (20-50%)?
- Does the air change two to five times per hour?
- Is 10/100/1000BASE-T Ethernet network cabling installed and in working order?
- Is a cabinet available to store material containers?
- Does the room have a door that can be closed and locked during installation?
- Is there a network connection? (Optional)
- Is there a telephone line? (Optional)

### PART FINISHING AREA

- Is adequate space available for the equipment and supplies? (See the section, "[Space Requirements](#)" on page 3)
- Is all construction to floors, ceilings, and walls complete and does it meet local building code specifications? Are floors clean and free of debris? Are floors easily cleanable with solvents?
- Have you decided what other equipment, accessories, and supplies you want to have with the ProX 800? Have you decided on a location for these items? (Refer to "[Site Selection - ProX 800](#)" on page 3)
- Has a compressed air connection with a pressure controller and fast closing connection been installed? (Optional for parts finishing)
- Is a workbench available that has negative pressure and electricity for power hand tools?
- Are electrical outlets and power available?
- Is there a 110/220V outlet available for the ProCure UV Curing chamber?
- Are there enough 110/220V outlets available in the room for equipment and tools?
- Have you installed the duct (if required) for ventilation of the ProCure UV Chamber?
- Is all the recommended safety equipment available, including nitrile gloves and wipes?

### WASTE DISPOSAL AND SAFETY

- Has a local waste disposal company been arranged for periodic pickup of waste materials?

### JOB SUBMISSION

(Workstations and Network Access)

- Has 3D Systems' software been loaded on at least one workstation so that we can submit a print job to the SLA system?
- Is the computer on the network?

**FAX this completed page to (803) 324-4311**

Completed by:

Customer Representative

Date

Assigned 3D Systems Customer Support

Engineer Forwarded Date

3D Systems provides this partial list of equipment and supplies of relevant accessories or supplies that are useful for handling, processing, or finishing SLA parts. Equipment and supplies are not limited to this list, and other vendors may provide similar or like products.



**NOTE: Customers are responsible for consulting local health, safety, and environmental regulations to determine additional site requirements. No information that is contained in this document constitutes legal advice regarding such requirements. 3D Systems has no responsibility to determine whether or not the customer is in compliance with applicable laws, nor do we guarantee the accuracy or quality of the supplier product.**

### Part Washing Systems

Custom large/oversize washers, or off-the-shelf models from:

#### RAMCO Equipment Corporation

32 Montgomery St.  
Hillside, NJ 07205  
Tel: 800-553-3650  
Fax: 908-687-0653

*Refer to these RAMCO products:*

MK36CSSX/TPM TPM Wash Unit  
MK36CSSX/WRU Water Rinse Unit  
SA-WRU Water Recycling Unit

### Uninterruptible Power Supply

#### American Power Conversion or Toshiba

5kVA

### Hand-Held UV Guns

#### DDU Enterprises

2909 Oregon Ct, Ste A2  
Torrance, CA 90503  
Tel: 310.781.1199 Fax: 310.781.9223

### Model Finishing Tools and Supplies

#### Micro-Mark

340 Snyder Ave.  
Berkeley Heights, NJ 07922  
Tel: 800.225.1066 Fax: 908.665.9383

#### Emerson Electric Co., Dremel Division

4915 21st St,  
Racine, WI 53406  
Tel: 414.554.1390 Fax: 414.554.7654

### UV Filter Screens (For Lights and Windows)

#### UV Process Supply, Inc.

1229 E. Courtland St.  
Chicago, IL 60614  
Tel: 800.621.1296 Fax: 312.880.6647

### Wipes

#### TexWipe Co. (TexSwab)

POB 308  
650 E Crescent Ave,  
Upper Saddle River, NJ 07458  
Tel: 201-327-9100

### Miscellaneous Supplies

*(available from many lab safety companies):*

- Cellulose Wadding (drain pads)
- Chemically Resistant Gloves (3D Systems recommends surgical-type 100% nitrile gloves)
- Eye Wash Stations
- Fire Extinguisher
- Fire Proof Waste Can
- Fire-resistant Storage Cabinets
- Lab Coats
- Neoprene Coated Gloves (for working with TPM)
- Tri-Propylene Glycol Monomethyl Ether (TPM)
- Safety Glasses (300-400 nm UV-blocking) — with side shielding

## 11 APPENDIX D: OBTAINING ASSISTANCE

When you need assistance with the installation of your SLA system, contact your 3D Systems Field Service Engineer or your 3D Systems Sales Representative.

### U.S.A.

3D Systems, Inc.  
333 Three D Systems Circle  
Rock Hill, SC 29730  
U.S.A.

General Inquiries: (803) 326-3900  
Material Orders: (800) 889-2964  
Customer Support: (800) 793-3669  
E-mail: [moreinfo@3dsystems.com](mailto:moreinfo@3dsystems.com)

### Germany

3D Systems GmbH  
Guerickeweg 9  
D-64291 Darmstadt,  
GERMANY

General Inquiries: +49-6151-357 0  
Material Orders: +49-6151-357 234  
Customer Support: +49-6151-357 357  
E-mail: [hotline.de@3dsystems.com](mailto:hotline.de@3dsystems.com)

### Hong Kong

3D Systems  
21st Floor  
Honest Motor Building  
9-11 Leighton Road Causeway  
Hong Kong

General Inquiries: (+852) 29 23 50 77  
Material Orders: (+852) 29 23 50 77  
Customer Support: (+852) 29 23 50 77  
E-mail: [asiainfo@3dsystems.com](mailto:asiainfo@3dsystems.com)

### Italy

3D Systems  
Via Archimede 42  
20041 Agrate Brianza  
(MI)  
ITALY

General Inquiries: (+39) 039 68904 00  
Material Orders: (+39) 039 68904 00  
Customer Support: +49 (0) 6151 357 357  
E-mail: [marketing.it@3dsystems.com](mailto:marketing.it@3dsystems.com)

### Thank You...

We at 3D Systems sincerely hope you will be happy with the purchase of your ProX 800. As a company, we are dedicated to developing a relationship with customers that extends beyond the terms of the sale. We are in the business of devising solutions to our customers' needs.

Please take the time to contact us with any questions, problems, suggestions, or other comments while working with our products, services, and people. Tell us about your applications, your successes, and your difficulties. We are constantly striving for higher quality, better products, and comprehensive services to benefit our customers.

### Japan

3D Systems Japan K.K.  
4-6-8 Tsurumaki  
Setagaya-ku,  
Tokyo 154-0016  
JAPAN

General Inquiries: (+81) 3 5451 1690  
Material Orders: (+81) 3 5451 1690  
Customer Support: (+81) 3 5451 1690  
E-mail: [japaninfo@3dsystems.com](mailto:japaninfo@3dsystems.com)

### U.K.

3D Systems Europe Ltd  
Mark House, Mark Road  
Hemel Hempstead  
Herts HP2 7UA  
UNITED KINGDOM

General Inquiries: +44 1442 282600  
Material Orders: +44 1442 282665  
Customer Support: +44 1442 282665  
E-mail: [marketing.uk@3dsystems.com](mailto:marketing.uk@3dsystems.com)

### Switzerland

3D Systems, Inc.  
PO Box 259  
1723 Marly  
Switzerland  
Tel.

+41-26-439 95 90

### France

3D Systems  
49, rue du Bois Chaland  
91090 Lisses  
FRANCE

Tél. : (+33) 01 60 87 88 77  
Fax : (+33) 01 60 87 07 66  
Email : [marketing@3dsystems.fr](mailto:marketing@3dsystems.fr)

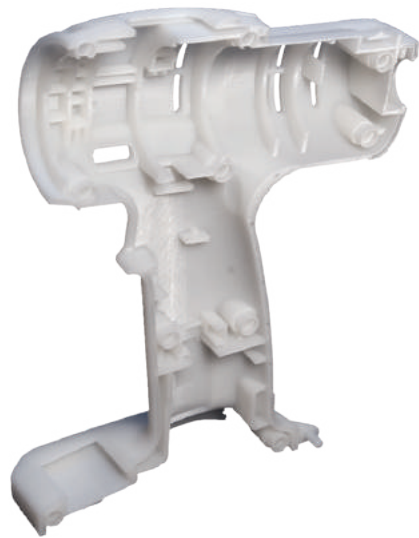

3D Systems, Inc.  
333 Three D Systems Circle | Rock Hill, SC | 29730  
[www.3dsystems.com](http://www.3dsystems.com)

©2014 3D Systems, Inc. All rights reserved.